

MATRIX LAM

## WORKING TABLE

WITH MEDIA HOLDER



### TITAN-1 OR 2 WITH EZ HOLDER

\*Media Holder is Optional Tool

*Authorized Dealer*

شركة النجم الرقمي للألات و المعدات  
DIGITAL STAR MACHINERY AND EQUIPMENTS

## Source of Digital Solutions...

Welcome to Digital Star, your trusted partner in the world of cutting-edge printing solutions. As a leading printing machines, materials, and ink authorized dealer in Riyadh – Saudi Arabia (KSA), we pride ourselves on delivering state-of-the-art technology that empowers to achieve unparalleled levels of efficiency and quality.

At Digital Star, we understand the pivotal role that printing machinery plays in the success of your operations. With a commitment to innovation and excellence, we curate a diverse range of top-tier printing machines to meet the unique needs of our clients. Our product line-up reflects the latest advancements in the industry.

As a responsible printing machines supplier, we prioritize sustainability. Our commitment to eco-friendly practices is reflected in the products we offer, promoting energy efficiency and environmentally conscious manufacturing processes. When you choose Digital Star, you're not just investing in cutting-edge technology – you're partnering with a company that values the planet as much as your success.

About Us



WORKING TABLE

# PRODUCT OVERVIEW

## Reliable working table

Matrix-Lam Glass working table is an ideal choice for sign making companies. You could choose from two size options:

### PARAMETER

SIZE	1300 X 1500MM / 1300 X 2500MM	Counter Top Glass	8mm Tempered
Adjustable Height	8cm	Table Material	Aluminum

- The table frame is made of high-quality aviation aluminum alloy, and his assembled and connected with cast aluminum corner connector.
- Countertop is covered by 8mm tempered glass (Passed 3C toughened certification), sealed with the aluminum profile frame by high quality glas adhesive.
- Height- Adjustable feet, height adjustable range 8cm.
- Countertop corners are made of ABS plastic, design with knife blade break slits and waste blade collection box for regular cleaning.

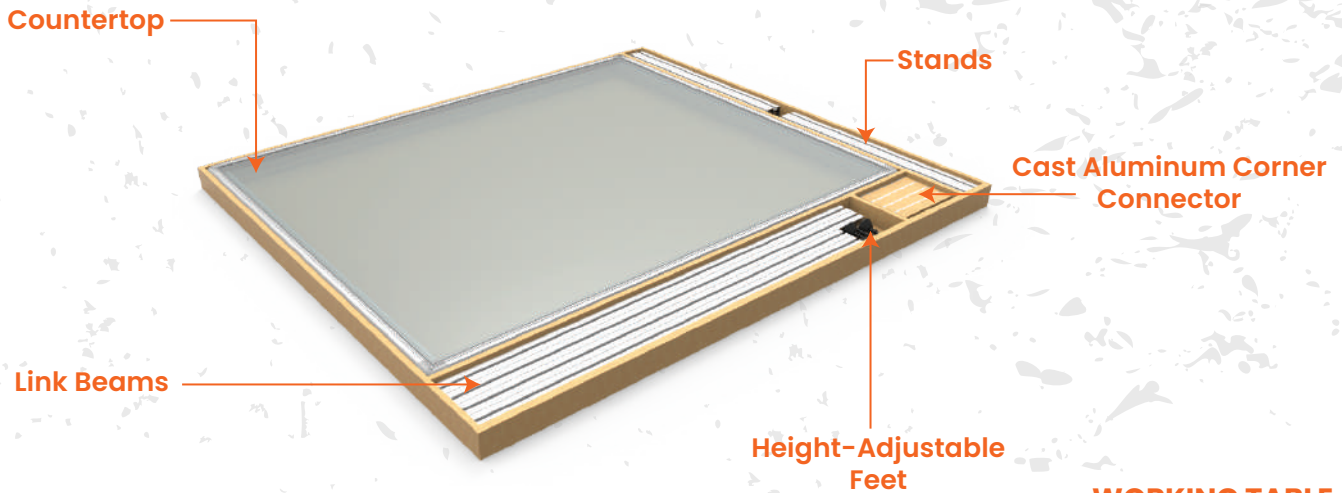

**WORKING TABLE**

### Practicality Paired with Aesthetics

One-piece wrap-around design of the table protects the surface of the workbench. It combines practicality with aesthetics and easy cleaning.

The working table was specifically designed to be compatible with a variety of Fayon post-processing tools. They could be easily installed, making work more convenient.



### Blade Breakers on the Corners

All 4 corners have blade breaking slots to make your work quicker thus improving efficiency.

When the knife blade is getting dull, you could just treak them with the slots designed on the four corners of the table. It also collects the discarded blades in an open-able flap bellow, which could be emptied periodically, allowing a smoother workflow.

## EZ MEDIA HOLDER (Optional)

MATRIX-LAM material holder built in Alloy Aluminum, helping user load prints on the table, which allow user easily pull out and flatten the prints.



#### PARAMETER

MAX. Loading Weight	120KGS	Rod Length	45cm
MAX. Loading Diameter	35cm	Gross Weight	1.5Kgs

## Loading Materials

It allows user to load the rolls materials on the top of table easily.  
We could use the EZ-Holders in pair to fit the different length/ width of materials.



## Film Feeding

Matrix-Lam EZ-Holder allows user pull up the packaging film very easy, which will save lots of labor and time



## Materials Unwinding

Thanks to the heavy weight of the rods and the base stands, we can pull out the materials roll to unwind easily. With the using of long-reach cutter, we can control the cutting position easily.

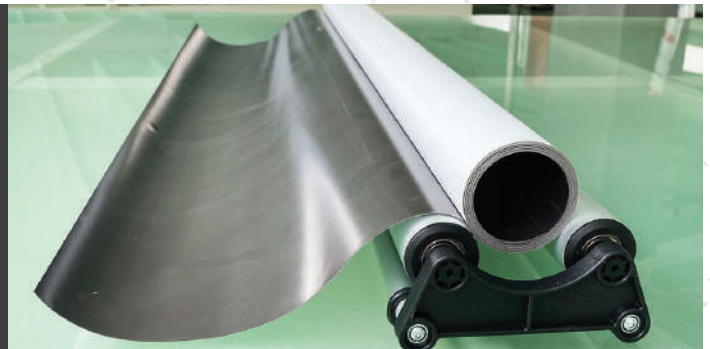

Thick anodized aluminum alloy Loading Roll

- Easy to Clean

High-quality smooth bearings

- Stronger bearing capacity and longer life

Reinforced nylon bracket

- Balance Strength and Beauty

Thickened aluminum alloy rod

- Ensure the strength of the Structure

Super wear-resistant Rubber Ring as feet

- Easy installation and Flexible use

Nickel plated High strength Bolts

- Rust-proof, wear-resistant and look beautiful



## Terms and Conditions

01. Payment to be made in SAR currency.
02. Payment Terms : As mentioned in Quotation.
03. Bank Charges: Any bank charges relevant to the above transactions will be to your account.
04. Any charges, duties, taxes or levies at the ports of entry will be to our account.
05. The charges of loading, boarding and local conveyance of the technician will be to our account.
06. Any required electrical, mechanical and civil site preparation should be done by the customer according to our engineer's requirements.
07. Digital Star Machinery and Equipments will not be held responsible for delays caused by any damage in the equipment due to shipment, unloading accidents & any related reasons, which is beyond our control.
08. Warranty will be applicable as per our Warranty Policies. The Warranty will be valid after signing of Warranty Policies.
09. Service will be free of cost within 12 months from the date of installation.
10. Any claim will be invoice directly to you then we will send for claiming procedure which will take 45-60 days, if the claim got approved credit note will issued directly.
11. Delivery: As mentioned in quotation

## شركة النجم الرقمي للألات و المعدات DIGITAL STAR MACHINERY AND EQUIPMENTS

IBN AL SAQA 8162 | AS SALHIYAH DIST | RIYADH - 12662



+966 11 229 4473



info@digitalstarksa.com



+966 11 229 4473



www.digitalstarksa.com