

MATRIX LAM

## SMART TABLE

FOR ALL SIZE PRINTS & KINDS OF BOARD



MXLM-S TABLE

*Authorized Dealer*

شركة النجم الرقمي للألات و المعدات  
DIGITAL STAR MACHINERY AND EQUIPMENTS

## Source of Digital Solutions...

Welcome to Digital Star, your trusted partner in the world of cutting-edge printing solutions. As a leading printing machines, materials, and ink authorized dealer in Riyadh – Saudi Arabia (KSA), we pride ourselves on delivering state-of-the-art technology that empowers to achieve unparalleled levels of efficiency and quality.

At Digital Star, we understand the pivotal role that printing machinery plays in the success of your operations. With a commitment to innovation and excellence, we curate a diverse range of top-tier printing machines to meet the unique needs of our clients. Our product line-up reflects the latest advancements in the industry.

As a responsible printing machines supplier, we prioritize sustainability. Our commitment to eco-friendly practices is reflected in the products we offer, promoting energy efficiency and environmentally conscious manufacturing processes. When you choose Digital Star, you're not just investing in cutting-edge technology – you're partnering with a company that values the planet as much as your success.

About Us



SMART TABLE

## PRODUCT OVERVIEW

Whether you're premasking cut letters, mounting prints onto boards or laminating, the Matrix will help you do job without wrinkles or bubbles resulting in a smooth finish everytime. Even over size prints can be finished with ease. What's more, it can be run with one operator making your shop more efficient!

### Minimal but not Simplify Design

Design and manufacture this professional, strong and durable laminator, aimed at guarantee the user's high quality processing effect and fast finished output everyday.



#### MOUNTING

It only takes one person to mount digital prints or adhesive stickers onto many form of substrights. Mount on foam board, corrugated pannels, metal panels, banners and glass, all without bubbles.

#### LAMINATING

Matrix- Lam samrt table can also be used for post processing laminating in cold or heat assist modes

### Manual Trimmer (Optional)

Make your trimming work: High quality, High speed, High safety!

- Aluminum alloy structure
- Two-way cutting design
- Safety knife Cover design
- Flexible for KT board, PVC cutting mat, Vinyl, thin PVC board  $\leq 2\text{mm}$ , thin prints materials. Unique patente design
- Easy blade replacement design can be installed on the end of tablet or workbench for using as an extended cutting tool



**SMART TABLE**

## Pneumatic Handle Valve Control

The table roll lifting is controlled by handle valve.  
Can stands 100,000 times reciprocation Pure mechanical structure, without internal electric circuits. Ergonomic design, comfortable grip feeling.

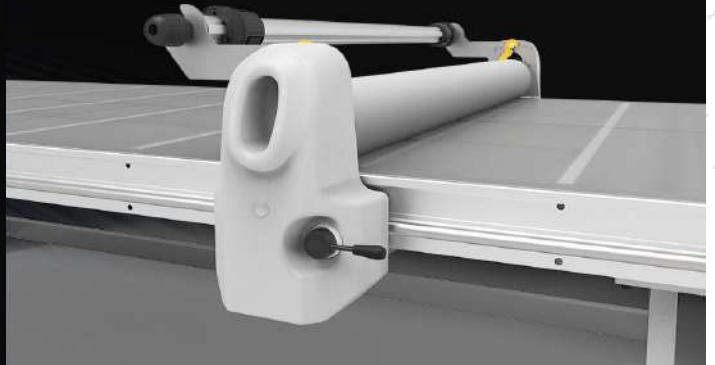

## Slim but strong Machine Body

Pure Alloy Aluminum Profile structure Laboratory level flat surface 10mm thickness Tempered Glass Anti-scratching and withstand impact all corners and edges are rounded



## Pneumatic Handle Valve Control

The table roll lifting is controlled by handle valve.  
Can stands 100,000 times reciprocation Pure mechanical structure, without internal electric circuits. Ergonomic design, comfortable grip feeling.



## Exclusive design of mechanical tension device

Invention Patent protection  
Tight and fix the core by twisting the black ring outer, which can keep the whole locking continuous stable.

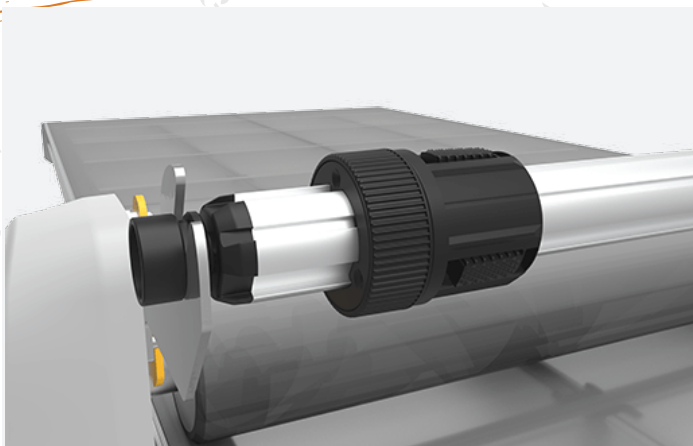

### Exclusive structure on the tension Knob

We chose the rectangular spring to get the process of increasing friction more smoothly and continuously, result in a better control of materials tension.

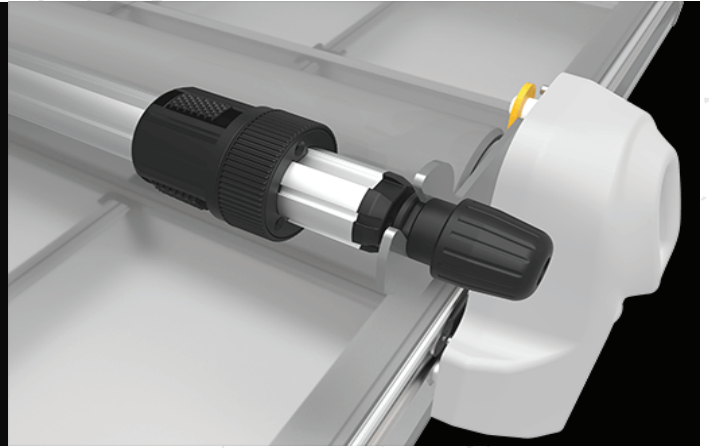

### Model: MXLM-S TABLE

Model	FY-1325	FY-1530
Max laminating size	1300/2500mm	1500/3000mm
Max laminating thickness	50mm	50mm
Operation type	Manual	Manual
Roller upgrade	Air cylinder	Air cylinder
Power input	0.8~1.0kw/h	0.8~1.0kw/h
Pressure range	0~0.8Mpa	0~0.8Mpa
N.W	380kgs	500kgs

\*Specifications are subject to change without prior notice, all rights reserved.

### PRODUCT SAMPLES



## Terms and Conditions

01. Payment to be made in SAR currency.
02. Payment Terms : As mentioned in Quotation.
03. Bank Charges: Any bank charges relevant to the above transactions will be to your account.
04. Any charges, duties, taxes or levies at the ports of entry will be to our account.
05. The charges of loading, boarding and local conveyance of the technician will be to our account.
06. Any required electrical, mechanical and civil site preparation should be done by the customer according to our engineer's requirements.
07. Digital Star Machinery and Equipments will not be held responsible for delays caused by any damage in the equipment due to shipment, unloading accidents & any related reasons, which is beyond our control.
08. Warranty will be applicable as per our Warranty Policies. The Warranty will be valid after signing of Warranty Policies.
09. Service will be free of cost within 12 months from the date of installation.
10. Any claim will be invoice directly to you then we will send for claiming procedure which will take 45-60 days, if the claim got approved credit note will issued directly.
11. Delivery: As mentioned in quotation

## شركة النجم الرقمي للألات و المعدات DIGITAL STAR MACHINERY AND EQUIPMENTS

IBN AL SAQA 8162 | AS SALHIYAH DIST | RIYADH - 12662



+966 11 229 4473



info@digitalstarksa.com



+966 11 229 4473



www.digitalstarksa.com